

**FFFLL****FREIGHTLINER**

Front suspension package  
Ensemble pour suspension avant  
Ensemble para suspensión de delantero

**INSTALLATION INSTRUCTIONS**

- Raise vehicle allowing the axle to hang freely.
- Remove top shock mounting bolts.
- Assemble Aeon rubber spring and bracket as shown in the adjacent diagram.
- Mount Timbren spring assembly between shock mount bracket and chassis frame.
- Tighten using Timbren fasteners provided - torque to OEM specifications.
- Lower vehicle.

**NOTES:**

Care must be taken to ensure that Aeon springs do not contact oil filter or starter motor when fully deflected.

**INSTRUCTIONS DE MONTAGE**

- Soulever le véhicule de sorte que l'essieu soit dégagé.
- Retirer les boulons supérieurs du montage élastique.
- Assembler le ressort en caoutchouc Aeon et le support comme il est indiqué dans le schéma adjacent.
- Monter le bloc de ressorts Timbren entre le support d'amortisseur et le cadre de châssis.
- Resserrer à l'aide de la boulonnerie fournie avec l'assemblage Timbren - effectuer une torsion selon les spécifications du fabricant d'équipement.
- Redescendre le véhicule.

**REMARQUES:**

Porter une attention particulière pour s'assurer que les ressorts Aeon n'entrent pas en contact avec le filtre à huile ou le démarreur lorsqu'ils sont entièrement défléchis.

Ne pas dépasser le poids nominal sur l'essieu recommandé par le fabricant du véhicule. Vérifier que le ressort AEON<sup>®</sup> n'a pas d'incidence sur d'autres pièces du véhicule - Le ressort AEON<sup>®</sup> augmentera son diamètre avec la charge.

Do not exceed vehicle manufacturer's recommended axle weight rating. Check for AEON<sup>®</sup> interference with vehicle components - Under load AEON<sup>®</sup> will "expand" in diameter.

**INSTRUCCIONES DE INSTALACIÓN**

- Levante el vehículo dejando que los ejes cuelguen libremente.
- Retire los pernos de montaje superiores del amortiguador.
- Ensamble el resorte de caucho Aeon y la abrazadera como se muestra en el diagrama adyacente.
- Monte la unidad de resorte Timbren entre la abrazadera de montaje del amortiguador y el armazón del chasis.
- Apriete utilizando los elementos de sujeción Timbren provistos - aplique par de torsión según las especificaciones del fabricante original de equipo.
- Baje el vehículo.

**NOTAS:**

Tenga cuidado y asegúrese de que de que los resortes Aeon no entren en contacto con el filtro de aceite o el motor de arranque cuando están totalmente flexionados.

No exceda la carga nominal en el eje recomendada por el fabricante del vehículo. Compruebe que no haya interferencia entre el resorte AEON<sup>®</sup> y los otros componentes del vehículo. Bajo carga, el resorte AEON<sup>®</sup> se ampliará en diámetro.

**Ref.** = Reference = No. de référence = Núm. de referencia  
**Part** = Part #. = No. de pièce = Núm. de pieza  
**Qty.** = Quantity = Quantité = Cantidad

Ref	Part	Qty
1	F31005-150	4
2	F40053-020	4
3	K10116-003	1L-1R
4	F11106-150	6
5	A25725-90AD00	2
6	A00540-55E60	2

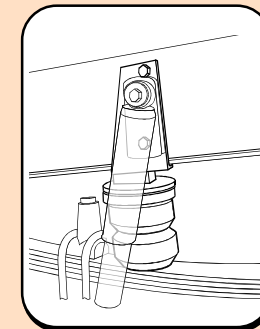
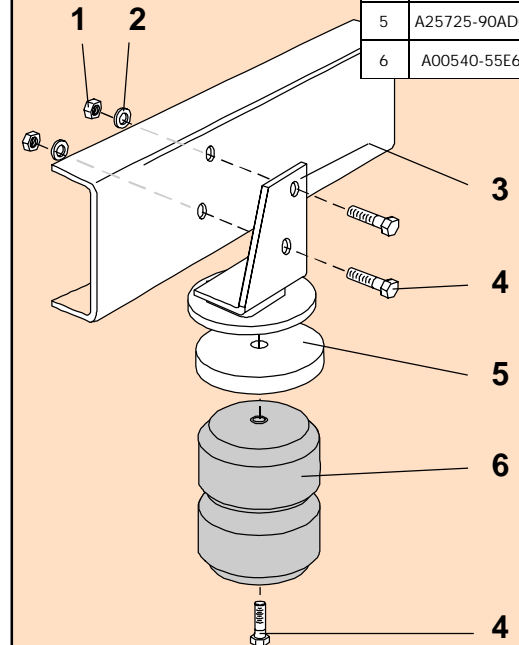

FFFLL

# TIMBREN SES

## Suspension Enhancement Systems



Ride Quality Control

Typical Light Duty Installation

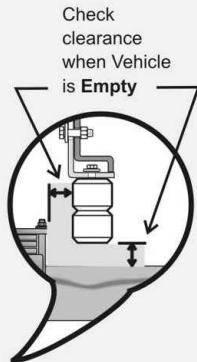

Check clearance when Vehicle is Empty

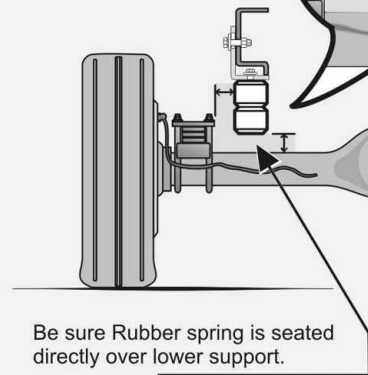

Be sure Rubber spring is seated directly over lower support.

Typical Medium & Heavy Duty Installation

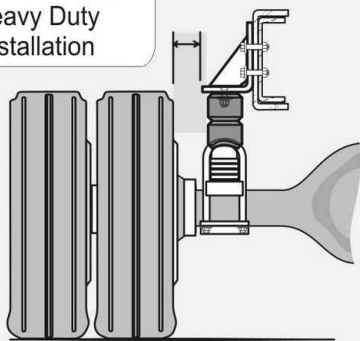

Timbren Industries Inc. ©

### Clearance Instructions

#### For Light Duty Pickups & Vans

Rear SES kits should have approximately 1" gap between rubber spring and axle for 1/2 and 3/4 tons, and for one ton the gap should be about 1/2" when the vehicle is completely unloaded. A cap or fifth wheel plate will reduce or eliminate this gap.

Front SES kits are usually in contact with the front suspension at all times.

#### For Medium Duty & Heavy Duty Trucks, Trailers, Motor Homes, and more

Medium & Heavy Duty vehicles often have pre-load as outlined in the instruction sheet. *(For specific Medium Duty applications with a constant load on the suspension like Rvs, Utility Vans or Cube Vans, the Timbren SES kits are pre-loaded.)*

**Check clearances when vehicle is empty...**

### Consider Your Needs..!

Knowing the use of the vehicle will help you to select the right SES kit. For example a one ton truck can be configured as a pick-up, service vehicle or tow truck. Standard capacity or severe service applications are available for many applications.

Knowing that the suspension has been modified or is old and sagging should indicate the need to adjust the ride height to obtain the correct clearance.

This can be done by altering the SES kit (changing rubber spring or bracket) or re-arching the leaf springs to renew the optimum OEM ride height.

## Lifetime Warranty

TIMBREN SES kits are warranted against defects in material and workmanship, under normal use and service, for the life of the vehicle on which the kit was originally installed. The warranty is not transferable and proof of purchase is required. The warranty is limited to the replacement of the failed part. TIMBREN will not be responsible for any labour or freight charges involved in the replacement of any product. TIMBREN shall be entitled to make its own inspection to determine the validity of the warranty claim. TIMBREN shall not be liable nor warrant the product in the event of alteration, misuse, overload, negligence or damage caused by others.

If ride or performance of our product is unsatisfactory in any way, please call:

**TIMBREN INDUSTRIES INC.**

**1-800-263-3113**



[www.timbren.com](http://www.timbren.com)

email: [sales@timbren.com](mailto:sales@timbren.com)