

FR1502D

FORD

Rear suspension package
Ensemble pour suspension arrière
Ensemble para suspensión de trasero

INSTALLATION INSTRUCTIONS

- Raise vehicle allowing the axle to hang freely.
- Remove existing bumpstop using 13 mm socket.
- Assemble Aeon rubber spring and bracket as shown in the adjacent diagram.
- Mount Timbren assembly using existing holes & Timbren supplied fasteners.
- Lower vehicle.

NOTES

Check that brake line or brake cable locations do not interfere with Aeon spring.

If necessary, use rubber washer #2 and bolt #5 to achieve desired ride height.

If OEM vehicle has a peg style casting as shown, Timbren Aeon® rubber spring is designed to contact peg. Do not remove OEM peg.

INSTRUCTIONS DE MONTAGE

- Soulever le véhicule de sorte que l'essieu soit dégagé.
- Enlevez la butée d'essieu existante en utilisant la douille de serrage de 13 mm.
- Assembler le ressort en caoutchouc Aeon et le support comme il est indiqué dans le schéma adjacent.
- Monter l'assemblage Timbren en utilisant les trous existants et la boulonnerie fournie avec l'assemblage Timbren.
- Redescendre le véhicule.

REMARQUES

Vérifier que les emplacements de la conduite de frein et du câble de frein ne nuisent pas au ressort Aeon.

Utiliser la rondelle en caoutchouc no 2 et fixer à l'aide de boulons la rondelle en caoutchouc no 5 pour obtenir le niveau du véhicule désiré.

Le ressort en caoutchouc Aeon® de Timbren est conçu pour entrer en contact avec le bras d'appui si le fabricant d'origine du véhicule en a installé un (voir le diagram). N'enlevez pas le bras de supporte du fabricant d'origine.

INSTRUCCIONES DE INSTALACIÓN

- Levante el vehículo dejando que los ejes cuelguen libremente.
- Quite el tope del eje existente utilizando una llave de cubo de 13 mm.
- Ensamble el resorte de caucho Aeon y la abrazadera como se muestra en el diagrama adyacente.
- Monte la unidad Timbren utilizando los orificios existentes y los elementos de sujeción Timbren provistos.
- Baje el vehículo.

NOTAS

Verifique que la ubicación de la tubería de freno o del cable del freno no interfiera con el resorte Aeon. Use arandela de caucho #2 y perno #5 para lograr el nivel deseado del vehículo.

El resorte de goma Aeon® de Timbren se concibe para entrar en contacto con el brazo de apoyo si el fabricante de origen del vehículo instaló uno (ver el diagram). No quite el brazo de soporte del fabricante de original del equipo.

Do not exceed vehicle manufacturer's recommended axle weight rating. Check for AEON® interference with vehicle components - Under load AEON® will "expand" in diameter.

Ne pas dépasser le poids nominal sur l'essieu recommandé par le fabricant du véhicule. Vérifier que le ressort AEON® n'a pas d'incidence sur d'autres pièces du véhicule - Le ressort AEON® augmentera son diamètre avec la charge.

No exceda la carga nominal en el eje recomendada por el fabricante del vehículo. Compruebe que no haya interferencia entre el resorte AEON® y los otros componentes del vehículo. Bajo carga, el resorte AEON® se amplía en diámetro.

Ref. = Reference = No. de référence = Núm. de referencia
Part = Part #. = No. de pièce = Núm. de pieza
Qty. = Quantity = Quantité = Cantidad

Ref	Part	Qty
1	K10468-003	1L-1R
2	A25723-90AH00	2
3	A00535-65Q30	2
4	F11538-350	2
5	F11543-350	2
6	F41308-050	2
7	F11536-350	2

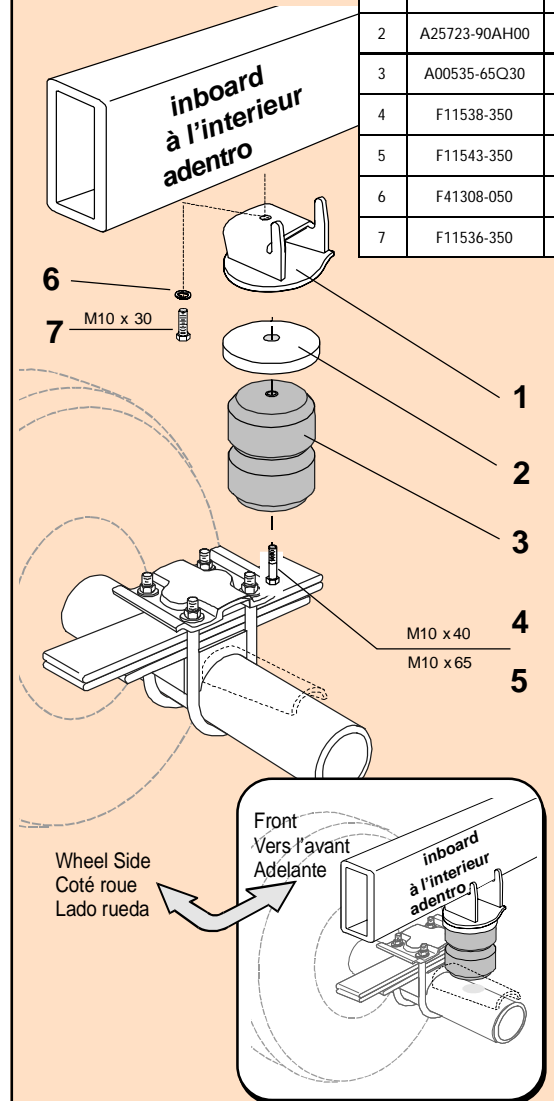

FR1502D

TIMBREN

TIMBREN SES

Suspension Enhancement Systems



Ride Quality Control

Typical Light Duty Installation

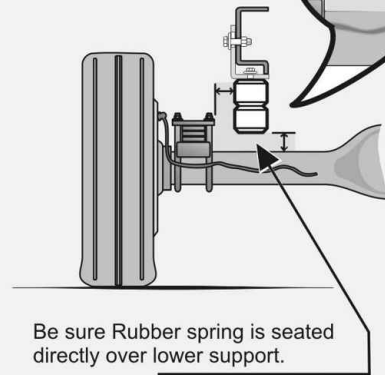

Be sure Rubber spring is seated directly over lower support.

Typical Medium & Heavy Duty Installation

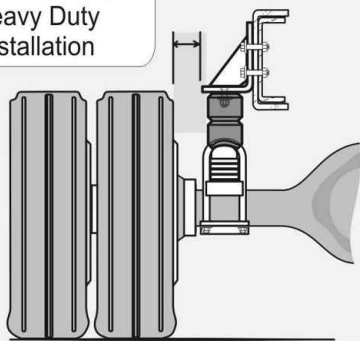

Check clearance when Vehicle is Empty

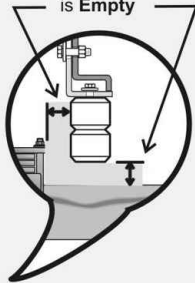

Timbren Industries Inc. ©

Clearance Instructions

For Light Duty Pickups & Vans

Rear SES kits should have approximately 1" gap between rubber spring and axle for 1/2 and 3/4 tons, and for one ton the gap should be about 1/2" when the vehicle is completely unloaded. A cap or fifth wheel plate will reduce or eliminate this gap.

Front SES kits are usually in contact with the front suspension at all times.

For Medium Duty & Heavy Duty Trucks, Trailers, Motor Homes, and more

Medium & Heavy Duty vehicles often have pre-load as outlined in the instruction sheet. (For specific Medium Duty applications with a constant load on the suspension like Rvs, Utility Vans or Cube Vans, the Timbren SES kits are pre-loaded.)

Check clearances when vehicle is empty...

Consider Your Needs..!

Knowing the use of the vehicle will help you to select the right SES kit. For example a one ton truck can be configured as a pick-up, service vehicle or tow truck. Standard capacity or severe service applications are available for many applications.

Knowing that the suspension has been modified or is old and sagging should indicate the need to adjust the ride height to obtain the correct clearance.

This can be done by altering the SES kit (changing rubber spring or bracket) or re-arching the leaf springs to renew the optimum OEM ride height.

Lifetime Warranty

TIMBREN SES kits are warranted against defects in material and workmanship, under normal use and service, for the life of the vehicle on which the kit was originally installed. The warranty is not transferable and proof of purchase is required. The warranty is limited to the replacement of the failed part. TIMBREN will not be responsible for any labour or freight charges involved in the replacement of any product. TIMBREN shall be entitled to make its own inspection to determine the validity of the warranty claim. TIMBREN shall not be liable nor warrant the product in the event of alteration, misuse, overload, negligence or damage caused by others.

If ride or performance of our product is unsatisfactory in any way, please call:

TIMBREN INDUSTRIES INC.

1-800-263-3113



www.timbren.com

email: sales@timbren.com