

FR350SDF**FORD**

Rear suspension package
Ensemble pour suspension arrière
Ensemble para suspensión de trasero

INSTALLATION INSTRUCTIONS

- Raise vehicle allowing the axle to hang freely.
- Remove existing bump stop & bushing. (See diagram A & B)
- Assemble Aeon rubber spring and bracket as shown in the adjacent diagram.
- Mount Timbren assembly using existing holes & Timbren supplied fasteners.
- Lower vehicle.

NOTES

Use rubber washer #5 and bolt #7 to achieve desired ride height.

Check that brake line or brake cable locations do not interfere with Aeon spring.

Use nut #9 at offset holes where required to position Aeon over axle.

2005-12 models, rotate bracket as shown, diagram C.

If OEM vehicle has a peg style casting as shown, Timbren Aeon® rubber spring is designed to contact peg. Do not remove OEM peg.

Do not exceed vehicle manufacturer's recommended axle weight rating. Check for AEON® interference with vehicle components - Under load AEON® will "expand" in diameter.

INSTRUCTIONS DE MONTAGE

- Soulever le véhicule de sorte que l'essieu soit dégagé.
- Retirer la butée de suspension existante et la douille. (voir le schéma A et B).
- Assembler le ressort en caoutchouc Aeon et le support comme il est indiqué dans le schéma adjacent.
- Monter l'assemblage Timbren en utilisant les trous existants et la boulonnerie fournie avec l'assemblage Timbren.
- Redescendre le véhicule.

REMARQUES

Utiliser la rondelle en caoutchouc no 5 et fixer à l'aide de boulons la rondelle en caoutchouc no 7 pour obtenir le niveau du véhicule désiré.

Vérifier que les emplacements de la conduite de frein et du câble de frein ne nuisent pas au ressort Aeon.

Utiliser l'écrou no.9 sur un des trous extérieurs pour centrer le ressort Aeon au-dessus de l'essieu.

Tourner le support tel que représenté sur diagram C pour les modèles de camions 2005-12.

Le ressort en caoutchouc Aeon® de Timbren est conçu pour entrer en contact avec le bras d'appui si le fabricant d'origine du véhicule en a installé un (voir le diagram). N'enlevez pas le bras de support du fabricant d'origine.

Ne pas dépasser le poids nominal sur l'essieu recommandé par le fabricant du véhicule. Vérifier que le ressort AEON® n'a pas d'incidence sur d'autres pièces du véhicule - Le ressort AEON® augmentera son diamètre avec la charge.

INSTRUCCIONES DE INSTALACIÓN

- Levante el vehículo dejando que los ejes cuelguen libremente.
- Retire la unidad del tope de suspensión existente y el buje. (Ver el diagrama A y B)
- Ensamble el resorte de caucho Aeon y la abrazadera como se muestra en el diagrama adyacente.
- Monte la unidad Timbren utilizando los orificios existentes y los elementos de sujeción Timbren provistos.
- Baje el vehículo.

NOTAS

Use arandela de caucho #5 y perno #7 para lograr el nivel deseado del vehículo.

Verifique que la ubicación de la tubería de freno o del cable del freno no interfiera con el resorte Aeon.

Utilizando la tuerca #9 sobre uno de los orificios para que el resorte Aeon está centrado sobre el eje.

Volver el soporte según lo demostrado en el diagrama C, para los modelos de camiones de 2005-12.

El resorte de goma Aeon® de Timbren se concibe para entrar en contacto con el brazo de apoyo si el fabricante de origen del vehículo instaló uno (ver el diagram). No quite el brazo de soporte del fabricante de original del equipo.

No exceda la carga nominal en el eje recomendada por el fabricante del vehículo. Compruebe que no haya interferencia entre el resorte AEON® y los otros componentes del vehículo. Bajo carga, el resorte AEON® se amplía en diámetro.

Ref. = Reference = No. de référence = Núm. de referencia
Part = Part #. = No. de pièce = Núm. de pieza
Qty. = Quantity = Quantité = Cantidad

Ref	Part	Qty
1	F11061-150	2
2	F41034-050	4
3	F40031-020	2
4	K10391-003	2
5	A25722-90P00	2
6	A00540-65Q30	2
7	F11065-150	2
8	F11063-150	2
9	F31003-150	2

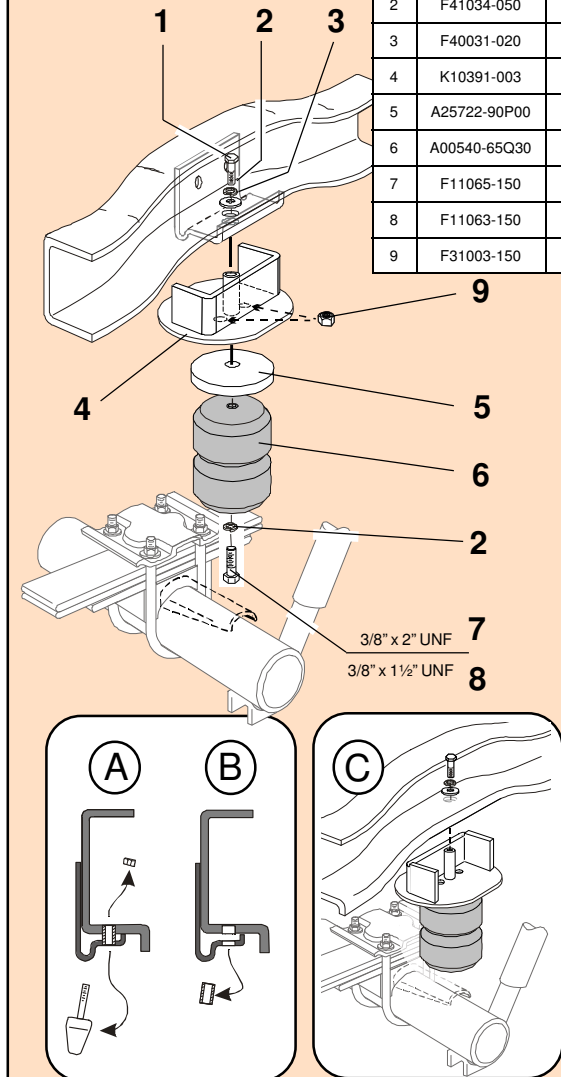

FR350SDF **TIMBREN**

TIMBREN SES

Suspension Enhancement Systems

Clearance Instructions



Ride Quality Control

Check clearance when Vehicle is Empty

Typical Light Duty Installation

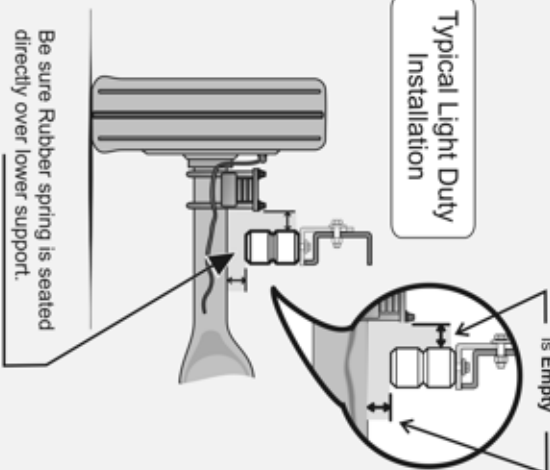

Typical Medium & Heavy Duty Installation

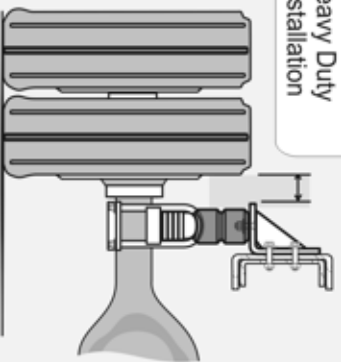

Timbren Industries Inc. ©

TIMBREN INDUSTRIES INC. © 10/02/09

For Light Duty Pickups & Vans

Rear SES kits should have approximately 1" gap between rubber spring and axle for 1/2 and 3/4 tons, and for one ton the gap should be about 1/2" when the vehicle is completely unloaded. A cap or fifth wheel plate will reduce or eliminate this gap.

Front SES kits are usually in contact with the front suspension

For Medium Duty & Heavy Duty Trucks, Trailers, Motor Homes, and more

Medium & Heavy Duty vehicles often have pre-load as outlined in the instruction sheet. (For specific Medium Duty applications with a constant load on the suspension like Rvs, Utility Vans or Cube Vans, the Timbren SES kits are pre-loaded.)

Check clearances when vehicle is empty...

Consider Your Needs..!

Knowing the use of the vehicle will help you to select the right SES kit. For example a one ton truck can be configured as a pick-up, service vehicle or tow truck. Standard capacity or severe service applications are available for many applications.

Knowing that the suspension has been modified or is old and sagging should indicate the need to adjust the ride height to obtain the correct clearance.

This can be done by altering the SES kit (changing rubber spring or bracket) or re-arching the leaf springs to renew the optimum OEM ride height.

Lifetime Warranty

TIMBREN SES kits are warranted against defects in material and workmanship, under normal use and service, for the life of the vehicle on which the kit was originally installed. The warranty is not transferable and proof of purchase is required. The warranty is limited to the replacement of the failed part. TIMBREN will not be responsible for any labour or freight charges involved in the replacement of any product. TIMBREN shall be entitled to make its own inspection to determine the validity of the warranty claim. TIMBREN shall not be liable nor warrant the product in the event of alteration, misuse, overload, negligence or

If ride or performance of our product is unsatisfactory in any way, please call:

TIMBREN INDUSTRIES INC.

1-800-263-3113



www.timbren.com

email: sales@timbren.com