

FRM2A

FREIGHTLINER

Rear suspension package Ensemble pour suspension arrière Ensemble para suspensión de trasero

INSTALLATION INSTRUCTIONS

- With vehicle unloaded & full air pressure measure 5" from the Timbren frame bracket to axle pad.
- When positioning frame bracket ensure that the Aeon spring rests over center of axle pad.
- Drill holes for Timbren bracket providing for at least four 5/8" Gr.5 bolts through the bracket & frame.
- Bolt frame bracket to frame using existing holes where possible.
- Assemble Aeon spring to bracket as shown in adjacent diagram.
- Weld Timbren lower assembly to axle.

NOTES:

OEM U-Bolt axle pad may have raised bump stop extension. Carefully remove this extension if it interferes with positioning of item # 8.

SAFETY CAUTIONS

Ensure sufficient clearance between frame bracket & tire. Always refer to and follow the vehicle manufacturer's guidelines when welding or drilling during installation of this kit.

OVERLOAD PREVENTION:

A working height less than 2" results in overload condition of item 5. If this condition exists during operation of vehicle, customer supplied mechanical stop to limit suspension travel must be used.

Do not exceed vehicle manufacturer's recommended axle weight rating. Check for AEON® interference with vehicle components - Under load AEON® will "expand" in diameter.

INSTRUCTIONS DE MONTAGE

- Calculer 5 po à partir du support du cadre Timbren jusqu'au coussin de l'essieu pour les véhicules à vide et plein de pression d'air.
- S'assurer, au moment de positionner le support du cadre, que le ressort Aeon demeure au centre du coussin de l'essieu.
- Percer des trous pour le support Timbren pouvant recevoir au moins quatre boulons de 5/8 po Gr.5 à travers le support et le cadre.
- Fixer à l'aide de boulons le support du cadre au cadre en utilisant les trous existants lorsque possible.
- Assembler le ressort Aeon au support comme il est indiqué dans le schéma adjacent.
- Souder l'assemblage inférieur Timbren à l'essieu.

REMARQUES:

La butée d'essieu avec boulons en U du fabricant d'origine peut avoir une extension. Enlevez soigneusement cette prolongation si elle interfère avec le positionnement No. 8.

MESURES DE SÉCURITÉ

Assurer un dégagement suffisant entre le support du cadre et les pneus. Se référer aux directives du fabricant et les suivre en tout temps lors du soudage ou du perçage en ce qui concerne l'installation du présent ensemble.

PREVENTION DE SURCHARGE:

Si le niveau de travail est moins de 2", une condition de surcharge s'exerce sur la pièce no. 5. Si cette condition se produit lors du fonctionnement du véhicule, alors il faut employer la butée d'arrêt.

Ne pas dépasser le poids nominal sur l'essieu recommandé par le fabricant du véhicule. Vérifier que le ressort AEON® n'a pas d'incidence sur d'autres pièces du véhicule - Le ressort AEON® augmentera son diamètre avec la charge.

INSTRUCCIONES DE INSTALACIÓN

- Con el vehículo descargado y presión neumática plena, mida 5" desde la abrazadera de chasis Timbren hasta el cojín amortiguador del eje.
- Al colocar en posición la abrazadera del chasis, asegúrese de que el resorte Aeon descansa sobre el centro del cojín amortiguador del eje.
- Perfore los orificios para la abrazadera Timbren previendo al menos para cuatro pernos de 5/8" Gr.5 a través de la abrazadera y el chasis.
- Atornille la abrazadera del chasis al chasis utilizando los orificios existentes donde sea posible.
- Ensamble el resorte Aeon a la abrazadera como se muestra en el diagrama adyacente.
- Suelde la unidad inferior Timbren al eje.

NOTAS:

El tope del eje con pernos en U del fabricante de origen puede tener una extensión. Retire cuidadosamente esta prolongación si interfiere con la localización #8.

PRECAUCIONES DE SEGURIDAD

Deje suficiente espacio libre entre la abrazadera del chasis y la llanta. Siempre consulte y siga las instrucciones del fabricante del vehículo al soldar o perforar durante la instalación de este kit.

PREVENCIÓN DE SOBRECARGA:

Si el nivel de trabajo es menos de 2", una condición de sobrecarga se ejerce sobre la parte #5. Si esta condición producirse en el funcionamiento del vehículo, entonces es necesario emplear el impulso de paro.

No exceda la carga nominal en el eje recomendada por el fabricante del vehículo. Compruebe que no haya interferencia entre el resorte AEON® y los otros componentes del vehículo. Bajo carga, el resorte AEON® se amplía en diámetro.

Ref. = Reference = No. de référence = Núm. de referencia
Part = Part #. = No. de pièce = Núm. de pieza
Qty. = Quantity = Quantité = Cantidad

Ref	Part	Qty
1	K10257-003	1L-1R
2	F11102-150	4
3	F11146-150	8
4	F40053-020	4
5	A00200-75V0B	2
6	F40071-020	8
7	F31007-150	8
8	K51265-005	2

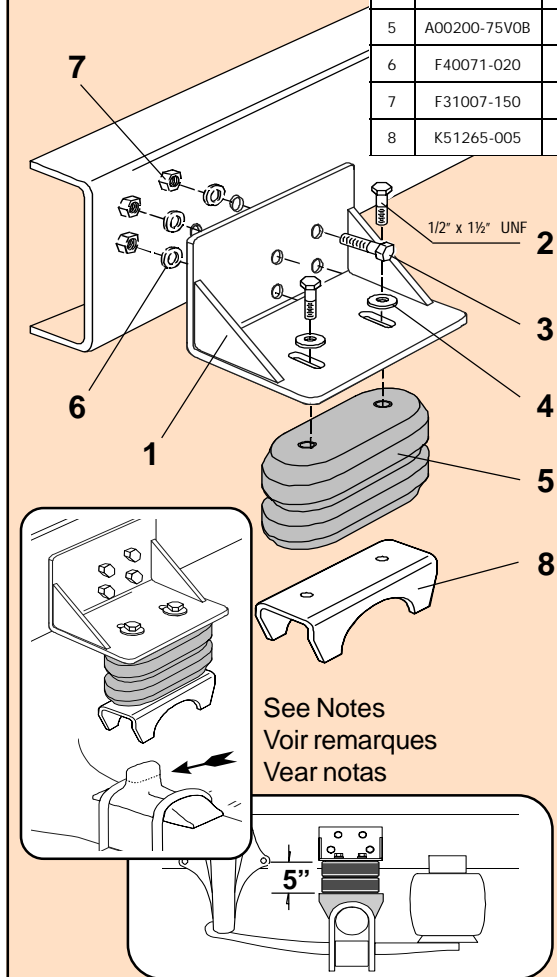

See Notes
Voir remarques
Vear notas

FRM2A

TIMBREN SES

Suspension Enhancement Systems



Ride Quality Control

Typical Light Duty Installation

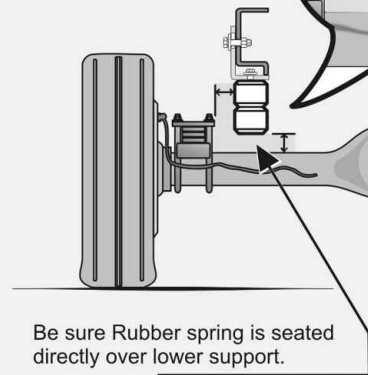
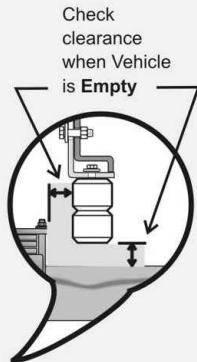

Typical Medium & Heavy Duty Installation

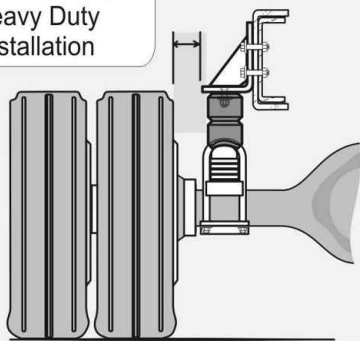

Timbren Industries Inc. ©

Clearance Instructions

For Light Duty Pickups & Vans

Rear SES kits should have approximately 1" gap between rubber spring and axle for 1/2 and 3/4 tons, and for one ton the gap should be about 1/2" when the vehicle is completely unloaded. A cap or fifth wheel plate will reduce or eliminate this gap.

Front SES kits are usually in contact with the front suspension at all times.

For Medium Duty & Heavy Duty Trucks, Trailers, Motor Homes, and more

Medium & Heavy Duty vehicles often have pre-load as outlined in the instruction sheet. (For specific Medium Duty applications with a constant load on the suspension like Rvs, Utility Vans or Cube Vans, the Timbren SES kits are pre-loaded.)

Check clearances when vehicle is empty...

Consider Your Needs..!

Knowing the use of the vehicle will help you to select the right SES kit. For example a one ton truck can be configured as a pick-up, service vehicle or tow truck. Standard capacity or severe service applications are available for many applications.

Knowing that the suspension has been modified or is old and sagging should indicate the need to adjust the ride height to obtain the correct clearance.

This can be done by altering the SES kit (changing rubber spring or bracket) or re-arching the leaf springs to renew the optimum OEM ride height.

Lifetime Warranty

TIMBREN SES kits are warranted against defects in material and workmanship, under normal use and service, for the life of the vehicle on which the kit was originally installed. The warranty is not transferable and proof of purchase is required. The warranty is limited to the replacement of the failed part. TIMBREN will not be responsible for any labour or freight charges involved in the replacement of any product. TIMBREN shall be entitled to make its own inspection to determine the validity of the warranty claim. TIMBREN shall not be liable nor warrant the product in the event of alteration, misuse, overload, negligence or damage caused by others.

If ride or performance of our product is unsatisfactory in any way, please call:

TIMBREN INDUSTRIES INC.

1-800-263-3113



www.timbren.com

email: sales@timbren.com