

GMFK15B

GM

Front suspension package Ensemble pour suspension avant Ensemble para suspensión de delantero

INSTALLATION INSTRUCTIONS

- Partially raise vehicle not allowing the axle to hang freely.
- For vehicles equipped with OEM stabilizer bar: Place spacer #7 between stabilizer bar and stabilizer end link as shown using bolt #8, OEM nut and Loctite®.
- Assemble Aeon rubber spring and bracket as shown in the adjacent diagram.
- Mount Timbren assembly using existing holes & Timbren supplied fasteners.
- Install in rear hole.
- Lower vehicle.

NOTE:

Turn wheels full lock both directions to ensure there is no interference with Timbren assembly.
When removing OEM fasteners, use penetrating fluid.

INSTRUCTIONS DE MONTAGE

- Soulevez légèrement le véhicule en ne permettant pas à l'axe de pendre librement.
- Pour des véhicules équipés d'une barre stabilisatrice du fabricant d'origine: Placez l'entretoise no. 7 entre la barre stabilisatrice et le lien en bout du stabilisateur tel que montré en utilisant le boulon no. 8, écrou d'origine et du Loctite®.
- Assembler le ressort en caoutchouc Aeon et le support comme il est indiqué dans le schéma adjacent.
- Monter l'assemblage Timbren en utilisant les trous existants et la boulonnerie fournie avec l'assemblage Timbren.
- Monter dans le trou arrière.
- Redescendre le véhicule.

REMARQUES:

S'assurer qu'il n'y a aucune interférence avec l'assemblage Timbren en tournant les roues complètement dans les deux directions.
Utiliser un fluide pénétrant, au moment de retirer la boulonnerie du fabricant d'équipement.

Do not exceed vehicle manufacturer's recommended axle weight rating. Check for AEON® interference with vehicle components - Under load AEON® will "expand" in diameter.

Ne pas dépasser le poids nominal sur l'essieu recommandé par le fabricant du véhicule. Vérifier que le ressort AEON® n'a pas d'incidence sur d'autres pièces du véhicule - Le ressort AEON® augmentera son diamètre avec la charge.

INSTRUCCIONES DE INSTALACIÓN

- Levante ligeramente el vehículo no permitiendo al eje colgar libremente.
- Para vehículos equipados de una barra estabilizadora del fabricante de origen: Coloque la riostra #7 entre la barra estabilizadora y el vínculo en final del estabilizador tal como se muestra utilizando el perno #8, tuerca d'origen y del Loctite®.
- Ensamble el resorte de caucho Aeon y la abrazadera como se muestra en el diagrama adyacente.
- Monte la unidad Timbren utilizando los orificios existentes y los elementos de sujeción Timbren provistos.
- Monte en el orificio de trasero.
- Baje el vehículo.

NOTAS:

Gire las ruedas hasta el tope en ambas direcciones para asegurarse de que no hay interferencia con la unidad Timbren.
Al remover los elementos de sujeción del fabricante original de equipo, utilice fluido penetrante.

No exceda la carga nominal en el eje recomendada por el fabricante del vehículo. Compruebe que no haya interferencia entre el resorte AEON® y los otros componentes del vehículo. Bajo carga, el resorte AEON® se amplía en diámetro.

Ref. = Reference = No. de référence = Núm. de referencia
Part = Part #. = No. de pièce = Núm. de pieza
Qty. = Quantity = Quantité = Cantidad

Ref	Part	Qty
1	F11536-350	2
2	F41308-050	4
3	F31051-350	2
4	K10445-003	1L-1R
5	A00180-75AG00	2
6	F13536-753	2
7	K41055-003	2
8	F11554-350	2

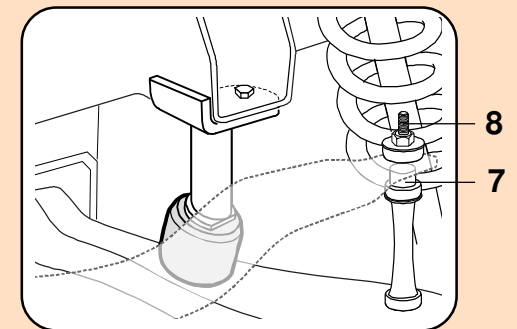
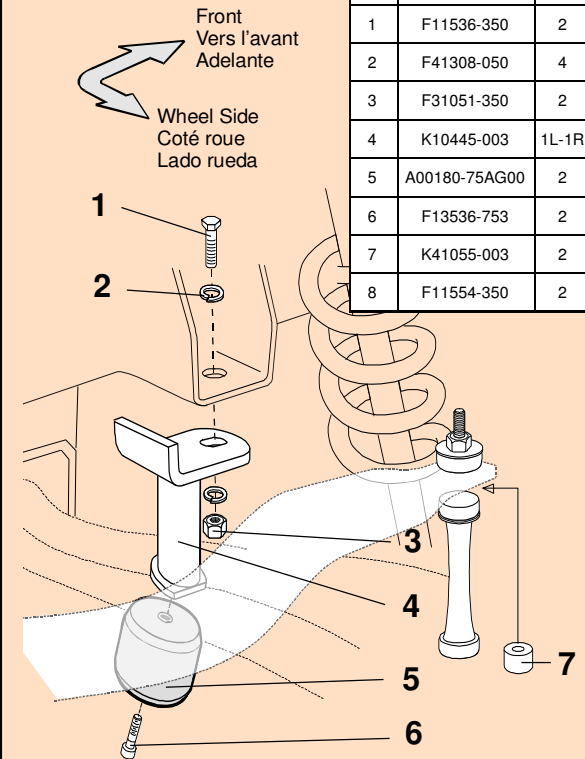

GMFK15B



TIMBREN SES

Suspension Enhancement Systems

Clearance Instructions

For Light Duty Pickups & Vans

Rear SES kits should have approximately 1" gap between rubber spring and axle for 1/2 and 3/4 tons, and for one ton the gap should be about 1/2" when the vehicle is completely unloaded. A cap or fifth wheel plate will reduce or eliminate this gap.

Front SES kits are usually in contact with the front suspension

For Medium Duty & Heavy Duty Trucks, Trailers, Motor Homes, and more

Medium & Heavy Duty vehicles often have pre-load as outlined in the instruction sheet. *(For specific Medium Duty applications with a constant load on the suspension like Rvs, Utility Vans or Cube Vans, the Timbren SES kits are pre-loaded.)*

Check clearances when vehicle is empty...

Consider Your Needs..!

Knowing the use of the vehicle will help you to select the right SES kit. For example a one ton truck can be configured as a pick-up, service vehicle or tow truck. Standard capacity or severe service applications are available for many applications.

Knowing that the suspension has been modified or is old and sagging should indicate the need to adjust the ride height to obtain the correct clearance.

This can be done by altering the SES kit (changing rubber spring or bracket) or re-arching the leaf springs to renew the optimum OEM ride height.

Lifetime Warranty

TIMBREN SES kits are warranted against defects in material and workmanship, under normal use and service, for the life of the vehicle on which the kit was originally installed. The warranty is not transferable and proof of purchase is required. The warranty is limited to the replacement of the failed part. TIMBREN will not be responsible for any labour or freight charges involved in the replacement of any product. TIMBREN shall be entitled to make its own inspection to determine the validity of the warranty claim. TIMBREN shall not be liable nor warrant the product in the event of alteration, misuse, overload, negligence or

If ride or performance of our product is unsatisfactory in any way, please call:

TIMBREN INDUSTRIES INC.

1-800-263-3113



www.timbren.com

email: sales@timbren.com



Ride Quality Control

Check clearance when Vehicle is Empty

Typical Light Duty Installation

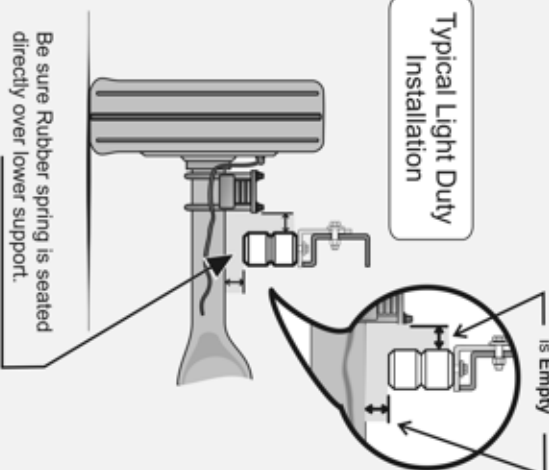

Be sure Rubber spring is seated directly over lower support.

Typical Medium & Heavy Duty Installation

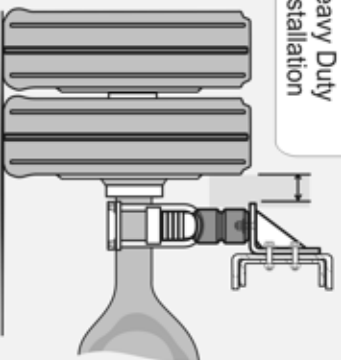

Timbren Industries Inc. ©