

HSR001

Front suspension package Ensemble pour suspension avant Ensemble para suspensión de delantero

INSTALLATION INSTRUCTIONS

- Choose the best location:
 - Center of U-bolt pad
 - Immediate Rear of U-bolt pad
- Assemble frame bracket by welding items #1 & #2 together keeping in mind the following:
 - Plate #2 should be positioned under bracket #1 to allow the Aeon spring to rest directly over the leaf spring
 - Bracket #1 will be bolted to the frame using existing holes where possible to ensure that the distance from the bottom of plate #2 to the top of leaf spring is 4-3/4 inches. Adjust accordingly with the use of spacers. (Diagram A)
- With vehicle unloaded, mount bracket to frame using at least three 1/2" Gr.8 bolts.
- Raise vehicle to install remainder of Timbren assembly.
- Lower vehicle.

NOTES:

Countersunk bolt #3 will need to be tack welded into place prior to welding items #1 & #2.

If necessary, drill to enlarge holes in frame to 9/16" diameter.

SAFETY CAUTIONS

Always refer to and follow the vehicle manufacturer's guidelines when welding or drilling during installation of this kit.

Do not exceed vehicle manufacturer's recommended axle weight rating. Check for AEON[®] interference with vehicle components - Under load AEON[®] will "expand" in diameter.

INSTRUCTIONS DE MONTAGE

- Choisir le meilleur emplacement :
 - au centre du coussin du boulon en U;
 - à l'arrière du coussin du boulon en U.
- Assembler le support du cadre en soudant les articles nos 1 et 2 ensemble en notant bien les éléments suivants :
 - la plaque no 2 doit être placée sous le support no 1 pour permettre au ressort Aeon de reposer directement sur le ressort à lames;
 - le support no 1 sera fixé à l'aide de boulons au cadre en utilisant les trous existants, lorsque possible, pour s'assurer que la distance entre la partie inférieure de la plaque no 2 et la partie supérieure du ressort à lames est de 4-3/4 po. Ajuster en conséquence à l'aide d'entretoises (voir le schéma A).
- Monter le support sur le cadre à l'aide d'au moins trois boulons de 1/2 po Gr.8 pour les véhicules à vide.
- Soulever le véhicule pour y installer le reste de l'assemblage Timbren.
- Redescendre le véhicule.

REMARQUES:

Souder par points le boulon à tête fraisée no 3 en place avant de procéder à la soudure des articles nos 1 et 2.

Perçer pour élargir les trous dans le cadre, si nécessaire, pour qu'ils aient 9/16 po de diamètre.

MESURES DE SÉCURITÉ

Se référer aux directives du fabricant et les suivre en tout temps lors du soudage ou du perçage en ce qui concerne l'installation du présent ensemble.

Ne pas dépasser le poids nominal sur l'essieu recommandé par le fabricant du véhicule. Vérifier que le ressort AEON[®] n'a pas d'incidence sur d'autres pièces du véhicule - Le ressort AEON[®] augmentera son diamètre avec la charge.

INSTRUCCIONES DE INSTALACIÓN

- Escoja la mejor ubicación:
 - En el centro del cojín amortiguador del perno U
 - Detrás del cojín amortiguador del perno U
- Ensamble la abrazadera del chasis soldando los ítems #1 y #2 entre sí teniendo en cuenta lo siguiente:
 - La placa #2 debe colocarse en posición debajo de la placa #1 para permitir que el resorte Aeon descansa directamente sobre el resorte de ballesta.
 - La abrazadera #1 será atornillada al chasis utilizando los orificios existentes donde sea posible para asegurar que la distancia desde la parte inferior de la placa #2 hasta la parte superior del resorte de ballesta es de 4-3/4 pulgadas. Ajuste de conformidad utilizando espaciadores. (vea diagrama A)
- Con el vehículo descargado, monte la abrazadera al chasis utilizando al menos tres pernos de 1/2" Gr.8.
- Levante el vehículo para instalar el resto de la unidad Timbren.
- Baje el vehículo.

NOTAS:

Se necesitará soldar por puntos en su sitio el perno avellanado #3 antes de soldar los ítems #1 & #2.

Si se necesita, perforo para ampliar los orificios en el chasis a 9/16" de diámetro.

PRECAUCIONES DE SEGURIDAD

Siempre consulte y siga las instrucciones del fabricante del vehículo al soldar o perforar durante la instalación de este kit.

No exceda la carga nominal en el eje recomendada por el fabricante del vehículo. Compruebe que no haya interferencia entre el resorte AEON[®] y los otros componentes del vehículo. Bajo carga, el resorte AEON[®] se ampliará en diámetro.

Ref. = Reference = No. de référence = Núm. de referencia
Part = Part #. = No. de pièce = Núm. de pieza
Qty. = Quantity = Quantité = Cantidad

Ref	Part	Qty
1	K51104-005	2
2	K52139-005	2
3	F12106-253	2
4	A01525-75G70	2
5	F31005-250	2

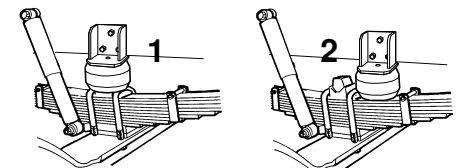
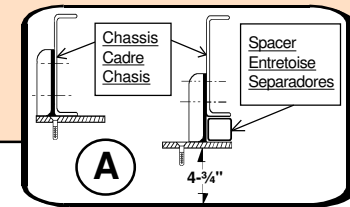
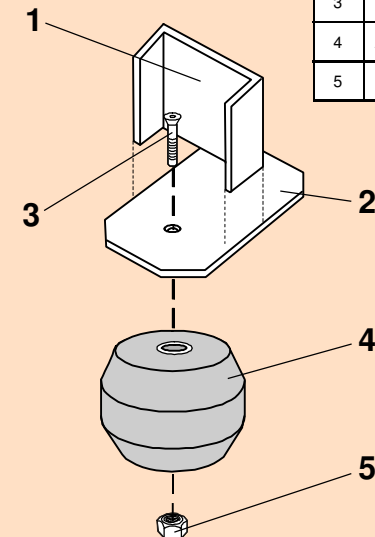

HSR001



TIMBREN SES

Suspension Enhancement Systems

Clearance Instructions

For Light Duty Pickups & Vans

Rear SES kits should have approximately 1" gap between rubber spring and axle for 1/2 and 3/4 tons, and for one ton the gap should be about 1/2" when the vehicle is completely unloaded. A cap or fifth wheel plate will reduce or eliminate this gap.

Front SES kits are usually in contact with the front suspension

For Medium Duty & Heavy Duty Trucks, Trailers, Motor Homes, and more

Medium & Heavy Duty vehicles often have pre-load as outlined in the instruction sheet. *(For specific Medium Duty applications with a constant load on the suspension like Rvs, Utility Vans or Cube Vans, the Timbren SES kits are pre-loaded.)*

Check clearances when vehicle is empty...

Consider Your Needs..!

Knowing the use of the vehicle will help you to select the right SES kit. For example a one ton truck can be configured as a pick-up, service vehicle or tow truck. Standard capacity or severe service applications are available for many applications.

Knowing that the suspension has been modified or is old and sagging should indicate the need to adjust the ride height to obtain the correct clearance.

This can be done by altering the SES kit (changing rubber spring or bracket) or re-arching the leaf springs to renew the optimum OEM ride height.

Lifetime Warranty

TIMBREN SES kits are warranted against defects in material and workmanship, under normal use and service, for the life of the vehicle on which the kit was originally installed. The warranty is not transferable and proof of purchase is required. The warranty is limited to the replacement of the failed part. TIMBREN will not be responsible for any labour or freight charges involved in the replacement of any product. TIMBREN shall be entitled to make its own inspection to determine the validity of the warranty claim. TIMBREN shall not be liable nor warrant the product in the event of alteration, misuse, overload, negligence or

If ride or performance of our product is unsatisfactory in any way, please call:

TIMBREN INDUSTRIES INC.

1-800-263-3113



www.timbren.com

email: sales@timbren.com



Ride Quality Control

Check clearance when Vehicle is Empty

Typical Light Duty Installation

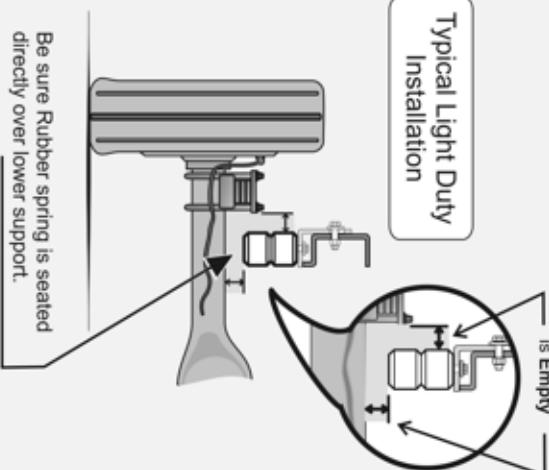

Be sure Rubber spring is seated directly over lower support.

Typical Medium & Heavy Duty Installation

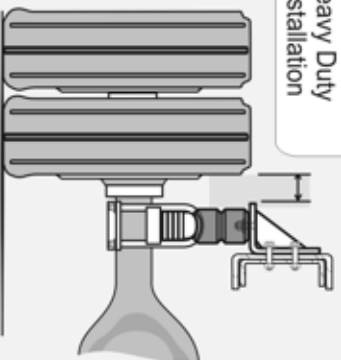

Timbren Industries Inc. ©